



The Joker – Fuzz bent out of shape

An electronics project by Aditya Advani

An experiment in noise

This project was built as part of my internship with Animal Factory Amplification (AFA)

Special thanks to Aditya Nandwana of AFA for the guidance and assisting me during every step of this build.

Why Fuzz?

After a few years of learning to play guitar I felt the need for a guitar processor that would allow me to copy some of the sounds of the bands and guitar players whose songs I was learning. After listening to a couple of processors my father and I eventually chose the Nova System from TC electronics as the sounds it made sounded the most natural to our ears.

We soon learned that the Nova System does not produce some of the sounds that I needed. The first sound I missed was the fuzz as I was trying to copy a Jimi Hendrix song. My dad suggested we buy a fuzz pedal and add it to the Nova System. Thankfully a friend of my father, Mr. Nandwana, had a company called Animal Factory Amplification that made some pedals and so I was gifted a fuzz pedal called the “Sonic Prism” to add to my Nova System. At the same time Mr. Nandwana also gifted me an “Ozymandias” distortion pedal but that is not related to this project.

One evening while I was playing I heard a horrible noise and I noticed it was coming whenever I turned the Sonic Prism Fuzz pedal on. I told my dad this and we decided to open the pedal to see if we could fix it. When we opened the Sonic Prism we noticed it was quite simple. My dad called up Mr. Nandwana to get it fixed and one thing led to another and Mr. Nandwana offered me a summer internship where I could build my own fuzz pedal and learn some electronics in the process.

Mr. Nandwana would provide me with the box for the pedal and my dad said he would buy me all the parts required to build this pedal. Meanwhile I started doing a bit of reading on Fuzz. I learned that there are several types of fuzz pedals and that the simplest of them used only 2 transistors and the most complex used as many as 5. I also learned that the sounds of these fuzz pedals varied considerably from the 2 transistor “Fuzz Face” to the 4 and 5 transistors “Big Muff”. Then a thought hit me. What if we could combine 2 fuzz sounds in one pedal? Would it work? I asked Mr. Nandwana and he said “Why Not?”

The Noisy World of Fuzz

I learned about the phenomenon of “clipping” and that both transistors and diodes (which is actually half a transistor) can do this. It is how they clip, and where exactly in the circuit they are that determines the sound they will produce.

You could have soft clipping (as shown in the green curve on the right below) or hard clipping where the wave was even more clipped (as shown in the red curve on the image right below)

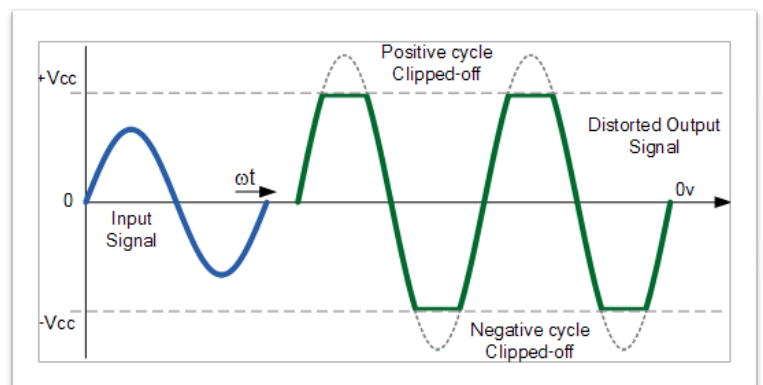

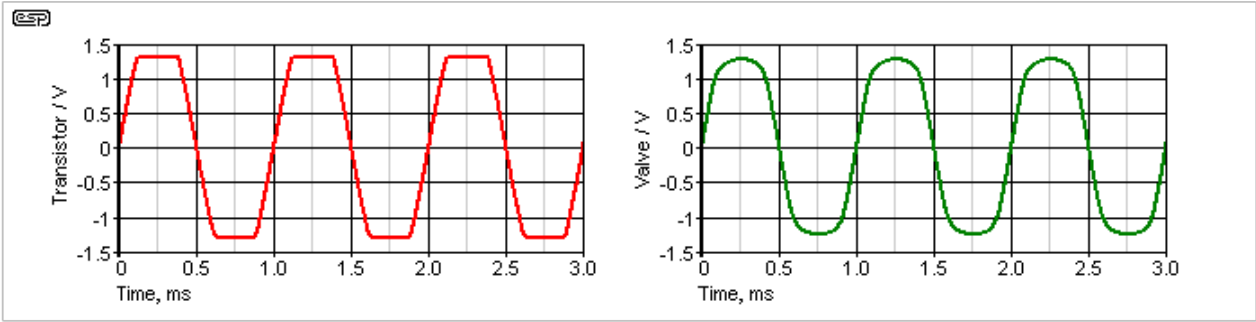

You could also have asymmetrical clipping when only one half of the sound wave was clipped (see below).

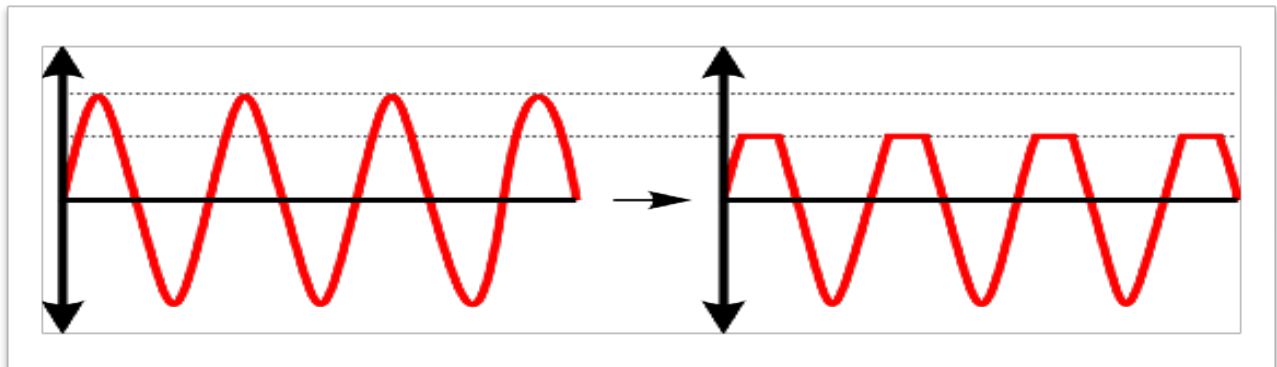

It was this clipping that produced several other sounds and created distortion and fuzz was just one of the several manifestations of this distortion.

In addition to basic clipping noise I also learned how transistors caused halfway rectified “octave-up” effects as seen in the circuit of the Foxx Tone Machine (above). “Halfway rectified” meaning that the original pitch was still heard in conjunction with the added higher octave (see below). So I figured I could add even this effect to my “double fuzz” pedal.

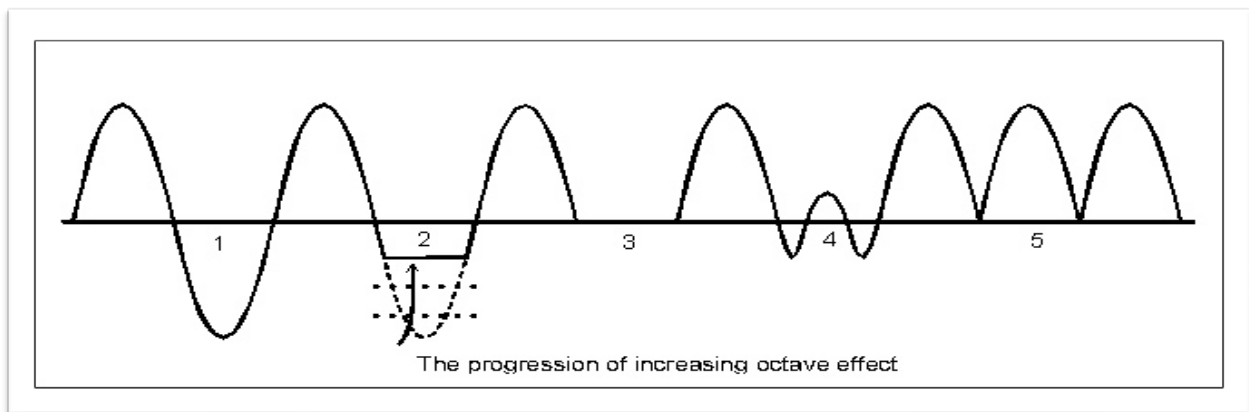

Octave effects - no octave at (1), halfway rectified at (3), fully rectified at (5)

With so many choices of circuits to choose from I needed help to choose. My goal was to narrow it down to 2 circuits and build the box so I could turn on and off the effect but with an additional switch to choose between 2 effects.

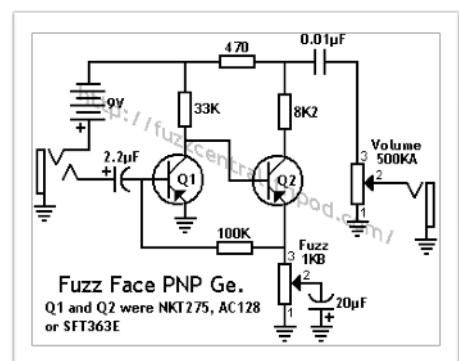

At this stage I had no idea how I was going to achieve this but with my dad and Mr. Nandwana helping me I was not so worried. Mr. Nandwana (who I learned has the same first name as me) was a ready and willing resource. His office was full of half-finished projects and he had several fuzz circuits I could try.

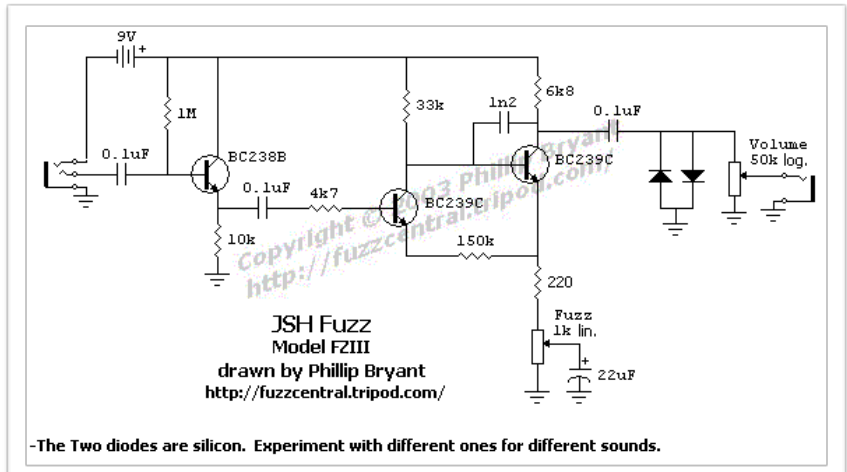

Some of the circuits I looked at are shown below. As you can see the "Foxx Tone Machine" and the "Big Muff Pi" looked the most complex and challenging so I decided to settle on these 2.

There are several variations of the Big Muff Pi but the basic version with 4 transistors seemed to be the best place to start.

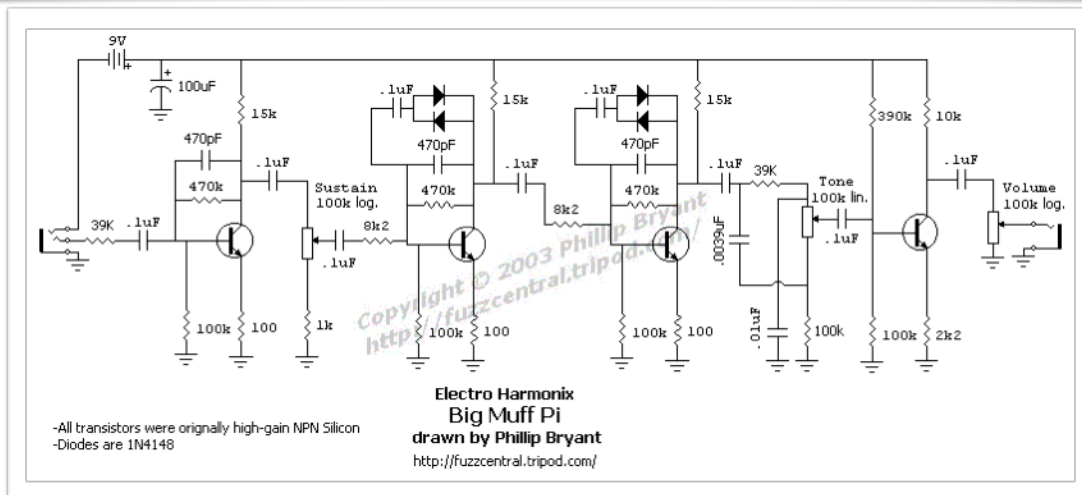
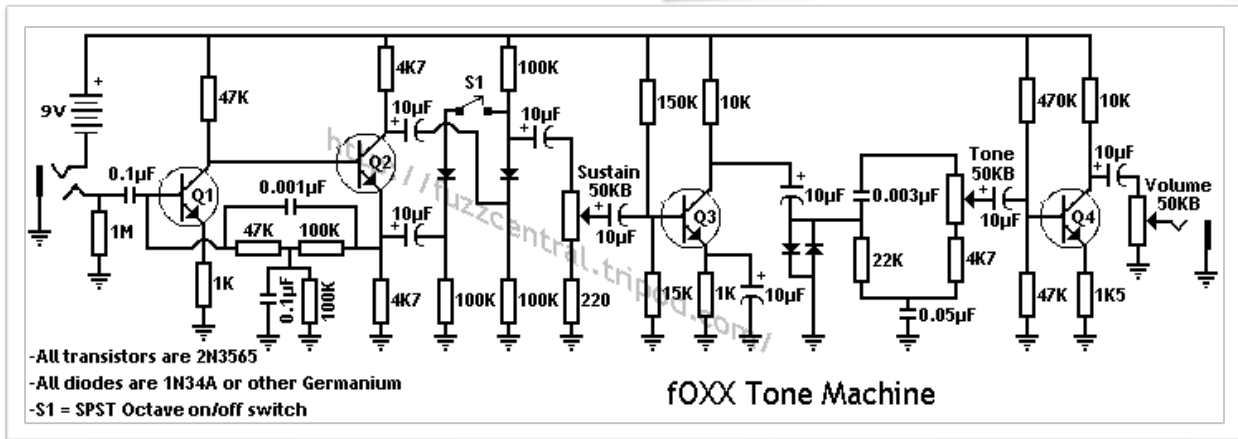
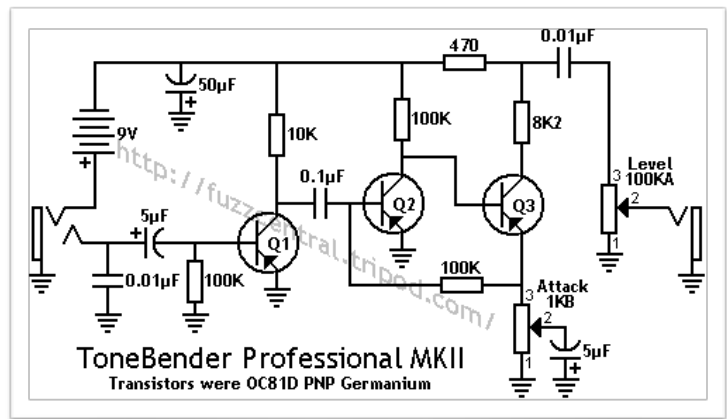

Let's Build

I was thoroughly tired and bored with all the explanations of the electronics and was more excited to actually build something. My father's friend became my new friend and I let him (Aditya Nandwana) worry about the electronics while I focused on my school work and thought about the graphics I could put on the box.

Aditya gave me a simple circuit to solder. It had only 2 transistors and a few resistors and capacitors. The circuit on paper looked simple but when I tried to solder the parts together it was a big mess. Aditya took one look at my soldering skills and started laughing. We threw my mess away and Aditya told me *"Soldering is all about learning by doing, you can't learn soldering by reading about it from a book"*.

Clearly, I did not have the skills to do this soldering so Mr. Nandwana decided to make it a little easier for me and figured it might be easier if I just get what is called Printed Circuit Boards (PCBs) for these electronic circuits as it would simplify the soldering part. I decided to google. I often wonder what people did before Google.

I googled a place in England called 'Fuzz Dog Pedal Parts' that sold PCBs for Guitar Pedals and we decided to buy 2 – one for the Foxx Tone Machine and one the Big Muff Pi. While browsing through their website I noticed that 'Fuzz Dog' also sold complete kits without the box (since we already had a box, knobs and switches) so I decided to ask my dad to order 2 complete kits instead. This way my project would not get stuck if one small electronic part was missing.

So we got 2 complete kits – one for the **Foxx Tave** (for the Foxx Tone Machine) and the other for the **Engorged Gherkin** (which was a variation of the Big Muff Pi). Links for both kits are provided at the end of this document.

My father bought me my own soldering iron and under the watchful eye of Mr. Nandwana I tried to solder the PCBs. The resistors were easy but some of the other components like the ICs were not, so Mr. Nandwana soldered them for me. To be honest, I think he did most of the work. I just watched.

While watching I got an idea to modify the Foxx Tone circuit to make it more usable - the Octave Up Switch should be a foot switch instead of a toggle switch. I could then use this feature while standing and playing guitar.

It took me 4 days (with some help from Aditya) to finish soldering both the PCBs. Aditya then inspected each PCB for something he calls "cold solder". A cold solder is when there is solder on the joint but for some reason there is no connection. Aditya tried to teach me how to recognise this by just looking through a magnifying glass but I could not.

Printed Circuit Boards all soldered in place

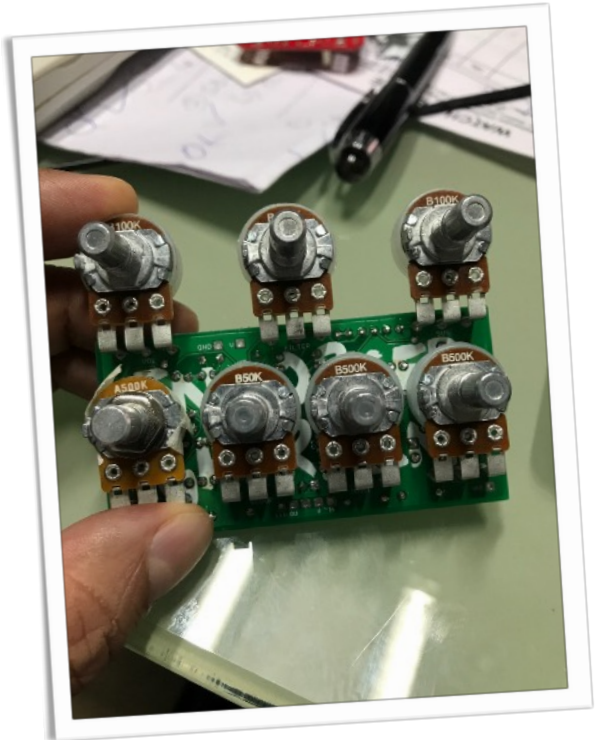

Engorged Gherkin (Big Muff Pi)

Foxx Tave (Foxx Tone Machine)

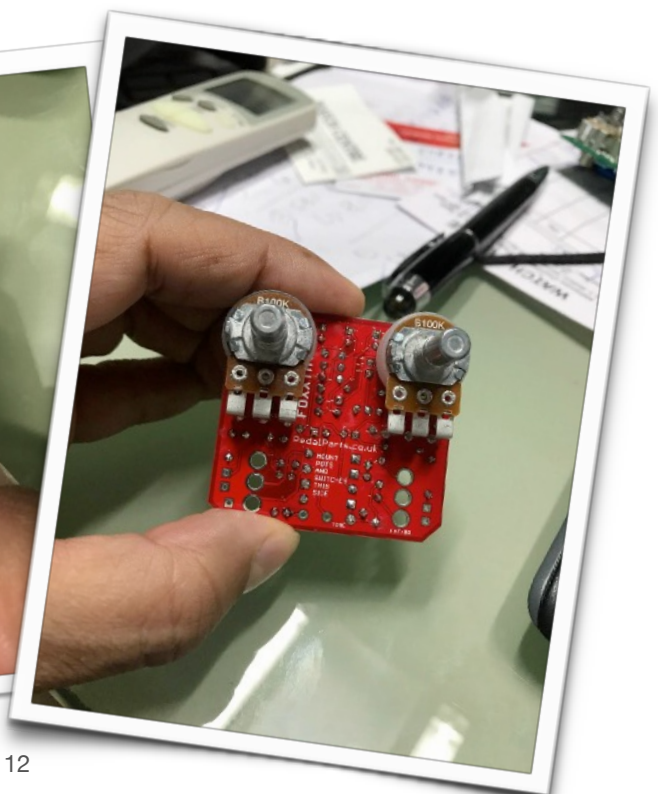
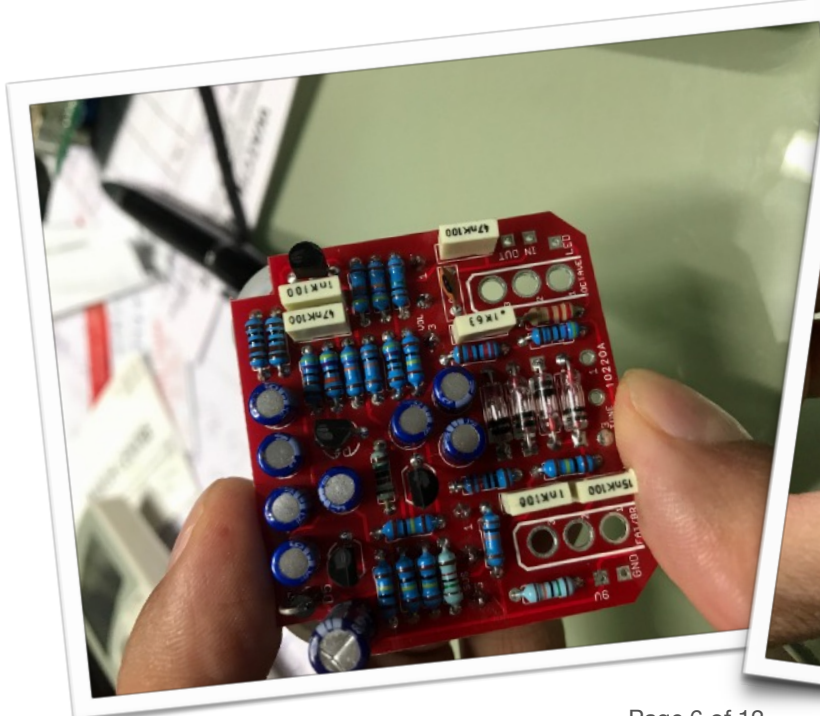

Building a layout

Now I had to design the top of the box to make sure all the knobs and switches with fit. Since I decided to use a foot switch for the octave switch (in the Foxx Tone Machine) I had to then visually balance the layout by moving the tone knob to location of the octave switch in the kit.

However, I had no software that could help be build a layout. I managed to download a 30 day trial copy of Trimble Sketchup so I could sketch the box and work on the locations of the switches and knobs that would need to fit on the box (link provided at the end of this document).

After several attempts and about 1 week of playing around with Sketchup this is what I produced. If it looks simple to you, let me assure you it was harder than it looks. Fortunately I had taken technical drawing for my ICSE (10th standard) and the skills I learnt there helped.

This was a far cry from box with some exciting graphics. However I was not so worried about this. Merging the sketch of the layout made with Sketchup to a graphics would be pretty easy with GIMP.

GIMP is an acronym for GNU Image Manipulation Program and can be used as an expert quality photo retouching program. The user can create layers and make layers transparent and hence stack several images on top of each other to create one composite image. It is very powerful and best of all it is free!

My aunt had already introduced me to GIMP a few years ago, so I was familiar with it. A link to GIMP and a basic You Tube video has been provided at the end of this document.

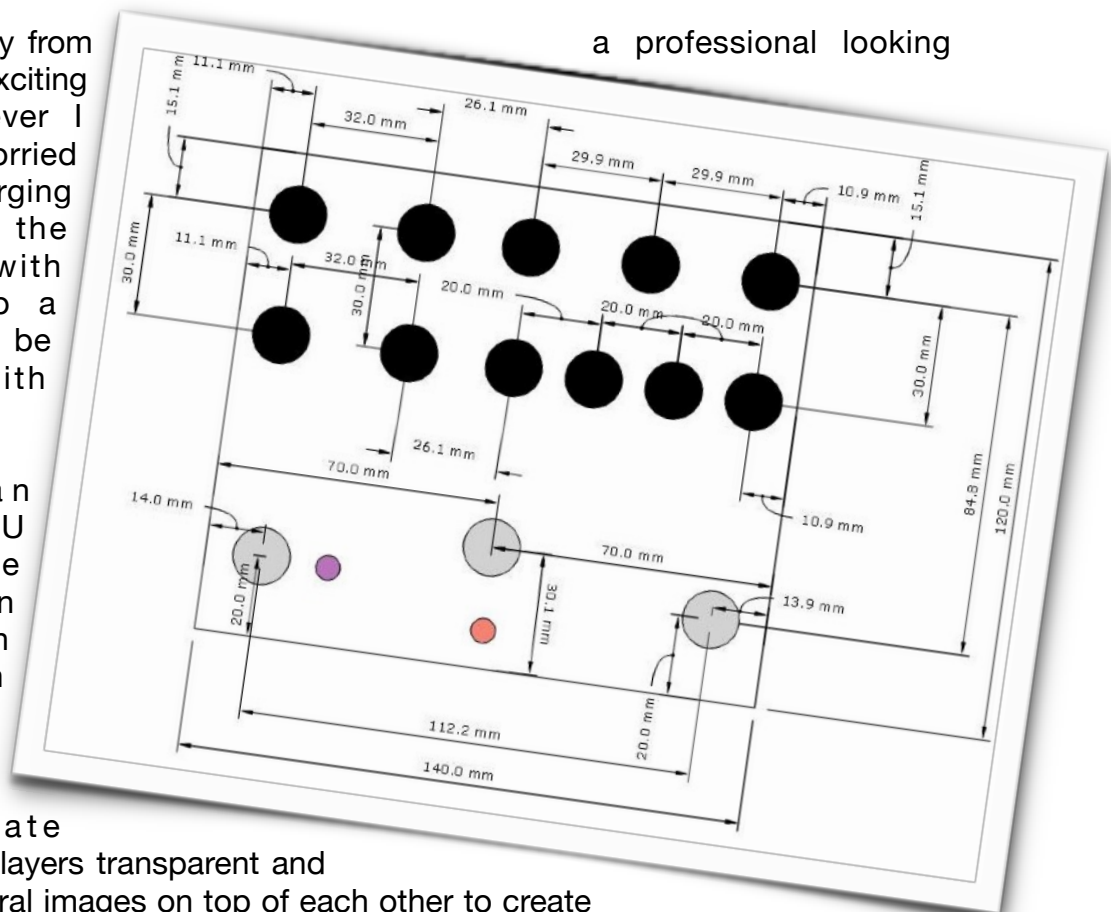

a professional looking

Testing The Joker

After building The Joker Mr. Nandwana decided he should test it. He has a sophisticated synthesizer that he built himself as his test bench. He put various sounds into The Joker and heard them.

I guess he knew what he sounds he was looking for and he really liked the octave feature that was in The Joker. He even compared The Joker on one of his own creations. I took it as a compliment.

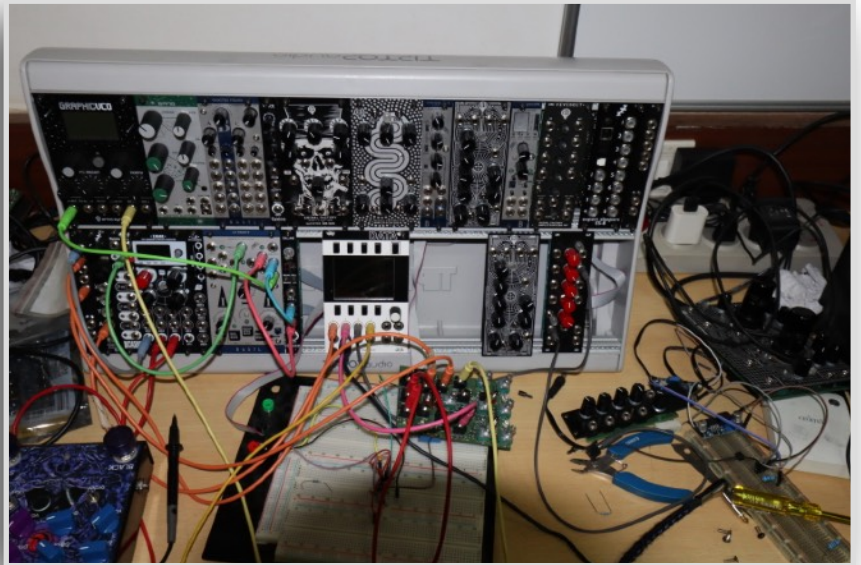

After about an hour of testing he finally gave it his ok. By some stroke of luck the first pedal I ever built was working well. If Aditya was as surprised as I was he never showed it but I was inspired to build another pedal and I already had an idea!

A short You Tube Video that explains the various forms of clipping
<https://www.youtube.com/watch?v=gj8cT7WEGmo>

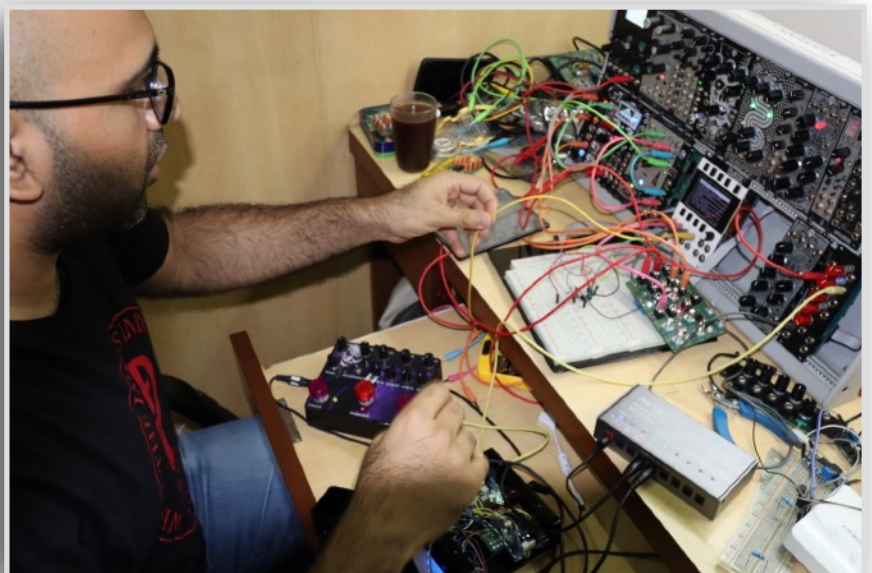

Other Links referenced to in this document

[https://www.tcelectronic.com/Categories/Tcelectronic/Guitar/Effects-Processors/NOVA-SYSTEM/p/P0CLX#googtrans\(en|en\)](https://www.tcelectronic.com/Categories/Tcelectronic/Guitar/Effects-Processors/NOVA-SYSTEM/p/P0CLX#googtrans(en|en))
http://www.bigmuffpage.com/Big_Muff_Pi_versions_schematics_part3.html
<http://www.fuzzcentral.ssguitar.com/fuzzface.php>
https://shop.pedalparts.co.uk/FoxxTave - Foxx Tone Machine Fuzz with Ultimate Options/p847124_11190624.aspx
https://shop.pedalparts.co.uk/Engorged_Gherkin_Fuzz/p847124_14535415.aspx
<https://www.sketchup.com/download>
<https://www.gimp.org/>
<https://www.youtube.com/watch?v=Q8C0LJPpr64&feature=youtu.be>
https://www.amazon.in/Colorite-Sheet-Adhesive-Inkjet-SAH135G420/dp/B00LVVWS7K/ref=sr_1_3?ie=UTF8&qid=1540976062&sr=8-3&keywords=self+adhesive+inkjet+photo+paper
https://www.amazon.in/Style-Up-printing-waterproof-adhesive/dp/B077W98D6W/ref=sr_1_2?ie=UTF8&qid=1540979016&sr=8-2&keywords=vinyl+paper+for+printing
<http://princedigraphics.com/>