

Oumuamua- Dark Noise

An Electronics Project by Aditya Advani

An experiment in noise- part 2

This project was built as a part of my internship with Animal Factory Amplification (AFA)

Special Thanks to Aditya Nandwana of AFA for the guidance and assisting me during every step of this build.



Oumuamua?

The Joker was interesting. I learned a lot. I thought why not build a distortion pedal?

The first challenge was choosing a concept. Then I heard of the mysterious, black, metal-rich, tumbling stone that raced through our solar system called Oumuamua! And Oumuamua it was!

Even before thinking about the electronics I was thinking of the graphics I could put on the box and was googling images. I still don't know where I found the image I finally used, but the moment I saw it, it looked to me like someone was looking into space from a trapezoidal window in a space ship made of bones – Pirates of the Caribbean in Space?



The Electronics

Now that I had the graphics I went looking for the electronics. The success I had with building The Joker emboldened me. I decided that Oumuamua would also be a dual pedal in one box. I always wondered what the real difference in sound between an overdrive and distortion were. I asked Aditya Nandwana and the explanation he offered was “Overdrive pedals are a soft clipping device that drive your valves **to the point of distortion**, while a distortion pedal is a hard clipping device that adds **lots of “grit” into the tone**. So I asked Aditya, “can I have both in one box?” and he said “yes”. Then I asked him “if I want to have both in one box, which should be first” and he said “there is no rule for that, either one can be first, maybe you can add a switch that can change the order of the effects”. So this would be Oumuamua – an overdrive and a distortion pedal in one box with a switch that can change the order in which the effects are used.

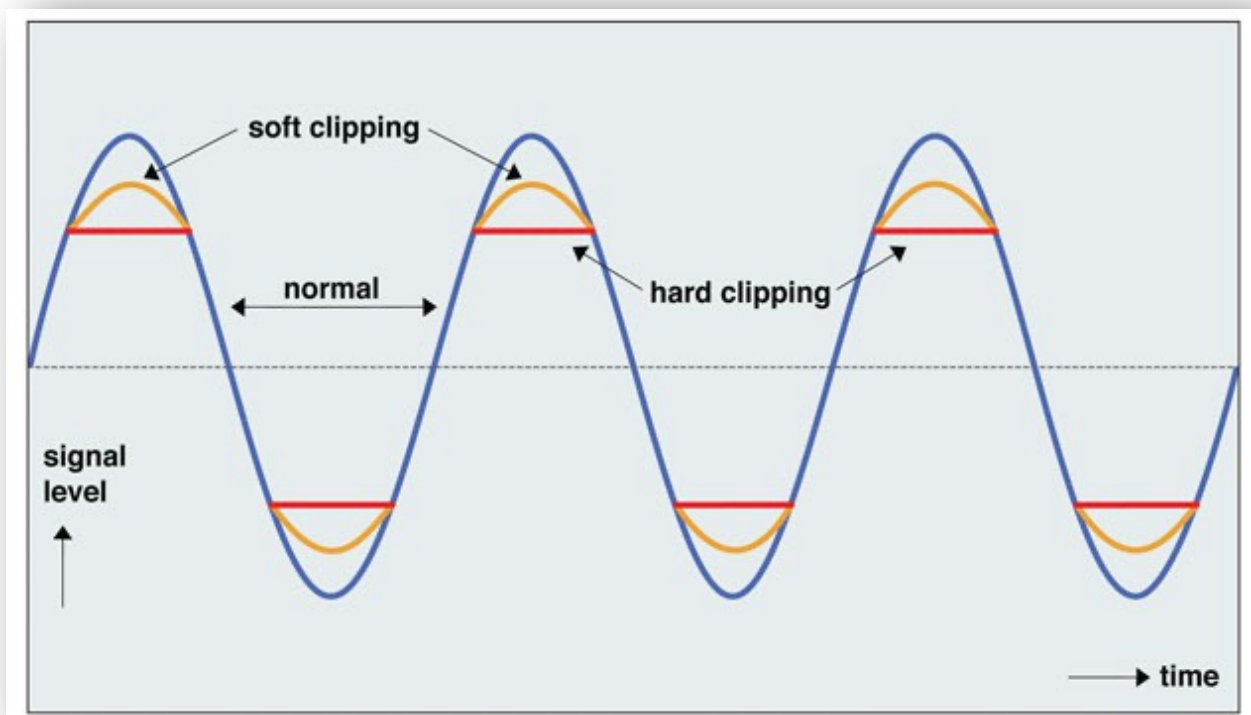

From my past experience with The Joker, I knew the fastest and easiest way to get all the parts was to look at some kits. Fuzz Dog had delivered good kits; that were complete with all the small parts for The Joker so that’s who I decided to order from this time too. Fuzz Dog has their kits categorised depending on how they modify the guitar’s sound. So I read up on all the kits in the ‘Overdrive/ Distortion’ category.

As explained above, I also wanted to incorporate 2 sounds into this project. However unlike The Joker where I could only choose 1 of the 2 sound effects I wanted to not only be able to choose either of the 2 effects, but also both together and even change the order of the circuits of the 2 effects.

Since the graphics was so busy, I decided to make the knobs and switches symmetrical so I decided

to short list only those kits that would have the same number of controls (in this case I settled for 4 controls per effect). I eventually settled on the ‘War Pig’ (a dark, muddy, distortion effect) and ‘Ampegulator’ (a bass heavy overdrive effect) as I was looking for a dark heavy gritty sound similar to what Black Sabbath produced in the 70s.

On Fuzzdog’s website, I also found a PCB that would permit me to switch the order of the 2 effects (linked at the end). The order switch circuit is explained in the schematic seen here. The centre leg of the FX-A and FX-B switches was used to switch an LED on and off. I used a single LED with Red and Blue lights so if both effects were on it would be purple, in keeping with the overall design of the purple box.

I also needed to order knobs for this project. I had not needed knobs for The Joker as I found the seven knobs required in Aditya Nandwana’s box of ‘spare parts’. This time, from Fuzz dog’s website, I chose knobs to match with the graphics – 4 purple and 4 blue.

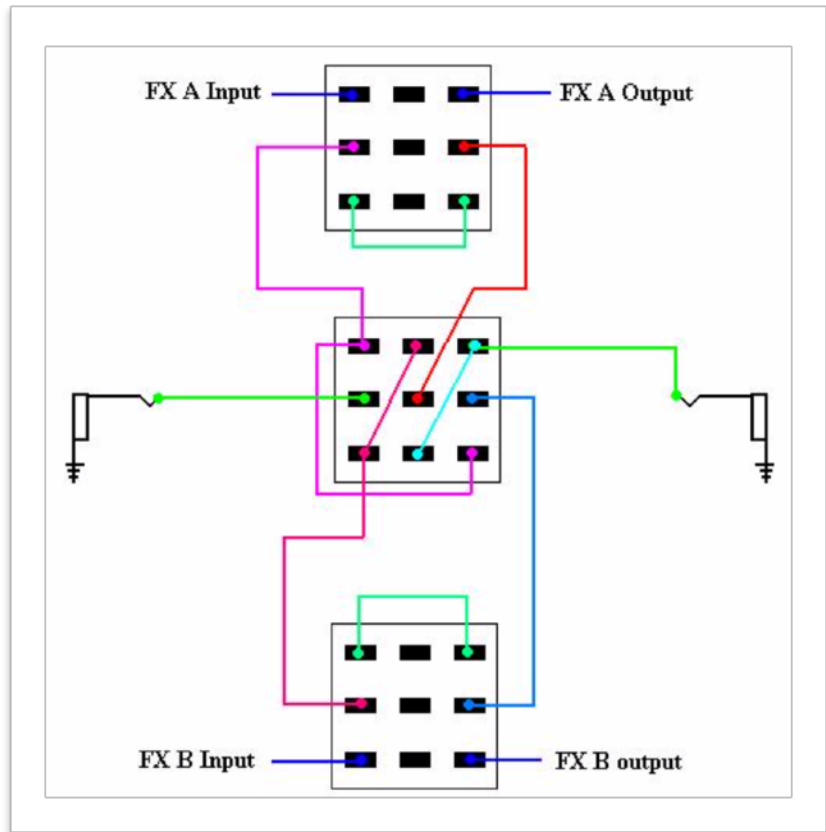

The ‘Ampegulator’ had a built-in option voltage doubler to increase the voltage from 9V to 18V. 9V DC is a standard option for all guitar pedals but some modern pedals can also operate at 18V. Using a voltage doubler I thought I might get 2 slightly different sounds. I wanted to see how much this difference from doubling the voltage would be. So I decided to use the voltage doubling circuit built in the Amegulator to provide 18V to both kits, the Ampegulator and the War Pig.

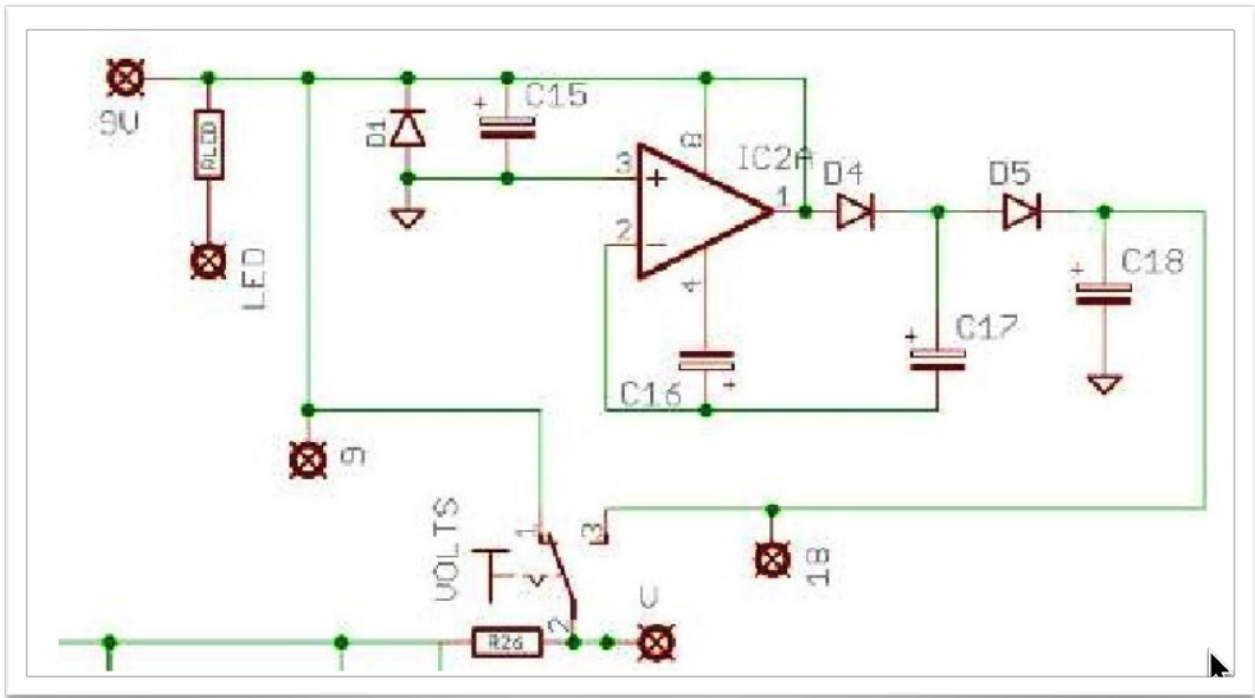

After ordering the kits and knobs I decided that I needed a box to fit all of this in. I wanted a square box because the graphics I had chosen was square. Sadly there was no square box to be found. I discussed the problem with my dad. After all he had also helped me order the kits.

My dad said maybe we can make one by bending some steel sheets. I now had all the parts required to start building.

Let's build

My 30 day trial of Trimble's Sketchup had expired so I had to find another software application to help me make my layout. After asking and googling a bit I settled on a program called Inkscape. Inkscape is totally free and hence the licence to use it would never expire. I highly recommend Inkscape as a sketching tool especially for those who use GIMP for the graphics as they combine well together. I used it to sketch the location of the holes for the Oumuamua.

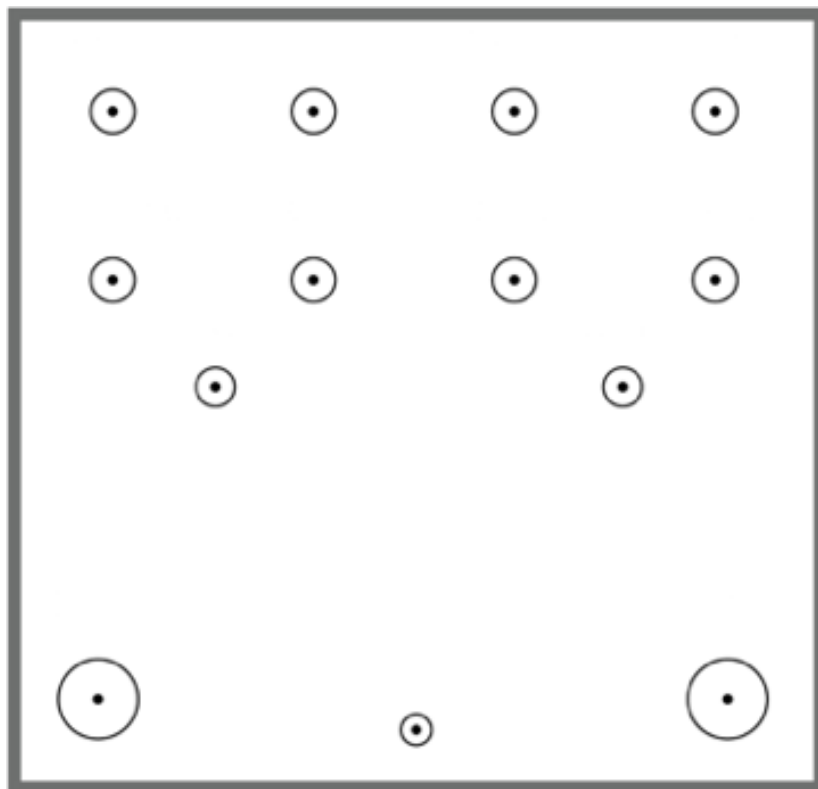

Since this project had 2 effects I needed to come up with 2 names. This was pretty simple - Oumuamua is a long Black Stone. Since 'Black' was also part of the name of the band 'Black Sabbath' on whose sound the 'War Pig' distortion is designed, 'Black' and 'Stone' were easy choices for the names of the effects.

By now I was more comfortable soldering PCBs which was lucky for me as my dad's friend Aditya Nandwana was too busy to help me. This is what the box looked like after I finished soldering the PCBs and wiring up the order switch.

Using GIMP for the graphics

I am quite familiar with GIMP so importing the sketch from Inkscape into GIMP was quite easy. I also found a vector pack (EPS file) for the knobs and switches and other hardware. This allowed me to make a realistic version of the pedal in GIMP.

This is what the top of the box looked in GIMP with the knobs and switches.



The Black switch was for the ‘Ampegulator’ and the Stone switch for the ‘War Pig’.

Printing the box was easier this time. My experience with The Joker had already taught me that UV printing is a very good option for metal boxes except that once the printing is done it needs to be covered in some transparent coating to protect the graphics from wear and tear. I discussed this with Mr. Karamjit of Prince DigiGraphics and he said he will apply a coat of lacquer as protection and that lacquer is quite transparent and will not distract from the graphics.

For printing I had to make a file that did not have the knobs and switches so this the image of the file I sent to Karamjit Singh of Prince DigiGraphics.



The picture on the right is the finished Oumuamua. It was a lot more difficult than I thought it would be. At times I thought I had bitten of more than I could chew and was really frustrated and wanted to quite but my dad would tell me “put it aside and come back to it tomorrow”.



I took the pedal to Aditya and he looked at the mess of wires and did not say a word. Till today I am not sure if he was impressed or thought I was the worst builder in the world.



Building the Oumuamua (Black Stone) was harder than building The Joker. I had less help from either my dad or Aditya Nandwana. I also tried to be more professional in the graphics by adding the knobs and switches. Inkscape is a boon and while it is slightly tougher than Sketchup there is no worry about licences.

Aditya took Oumuamua to his test bench. One half of the pedal measured fine but he could hear some popping. The second half of the pedal sounded like all the high frequencies had been removed. So we had problems.

Would I do this again? Maybe, but I am quite exhausted. For now, I have decided to take a break from electronics and concentrate on my school work.

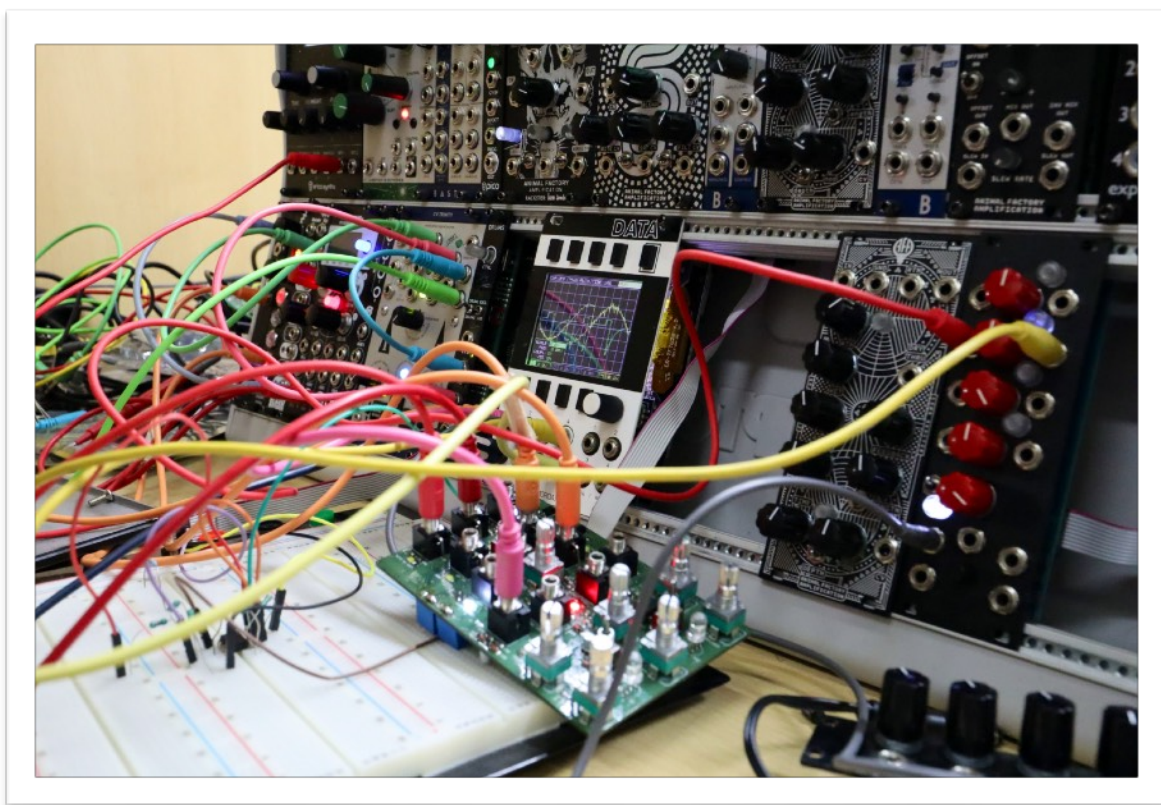

Testing both pedals: The Oumuamua and The Joker

Aditya Nandwana then took me to his studio to test both my pedals. We played various forms of music from various synthesisers and heard the effects on his speakers. This was a fun day for me - playing with all the sounds.



Links referenced to in this document

<http://pedalparts.co.uk/docs/Ampegulator.pdf>
<http://pedalparts.co.uk/docs/WarPig.pdf>
<http://pedalparts.co.uk/docs/OrderSwitcher.pdf>
<https://inkscape.org/>
<http://www.ontheroadeffects.com/vectorpack/>